



# MIOL-B-ExD MIOL-C-ExD

**MEDIUM  
INTENSITY**

Medium intensity obstruction light multiled type, compliance to ICAO type B, type C and FAA L-864, single or twin, night only.

- Based on led technology
- Steady burning red light for MIOL-C
- Flashing red light for MIOL-B (20-60 fpm)
- Long life time >10+ years expectancy
- Stabilized light output
- Ex certificate nr. INERIS 01 ATEX 0019X Exd IIC T4

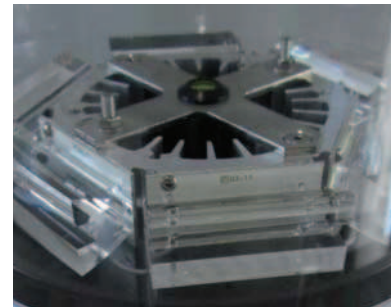

**Order Code**

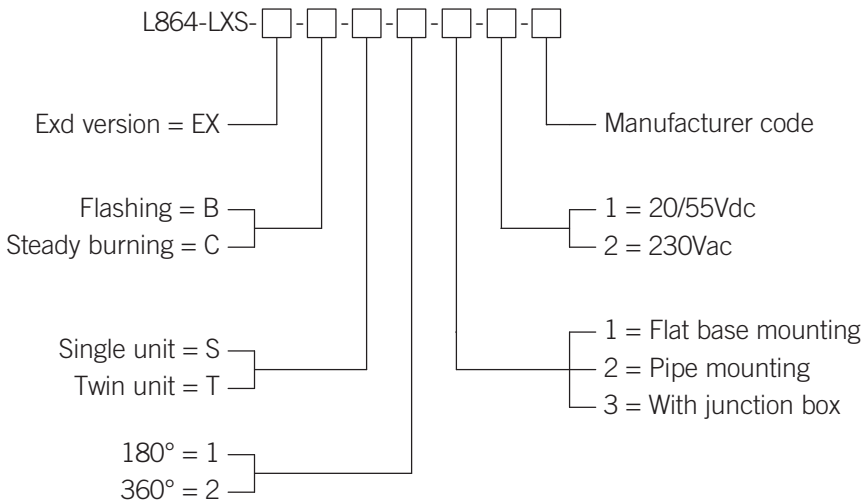

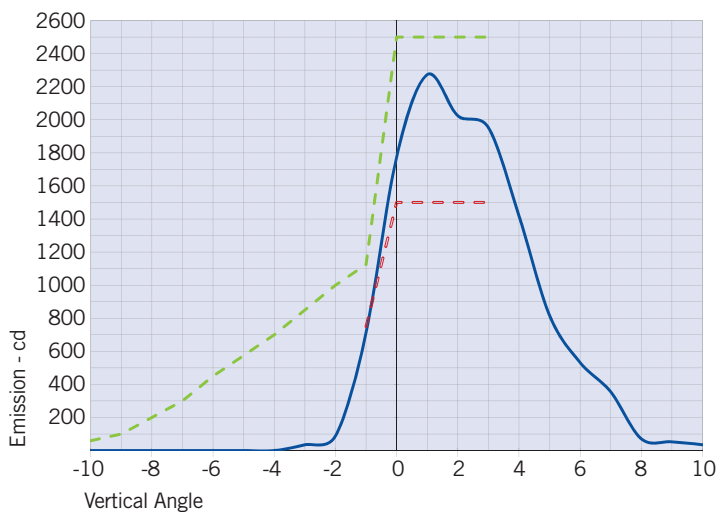

- L864-LXS-B average emission level at 90°C ambient temperature
- ICAO ANNEX 14 medium intensity type B/C Minimum Required Intensity
- ICAO ANNEX 14 medium intensity type B/C Maximum Required Intensity

BEACON FRONT VIEW

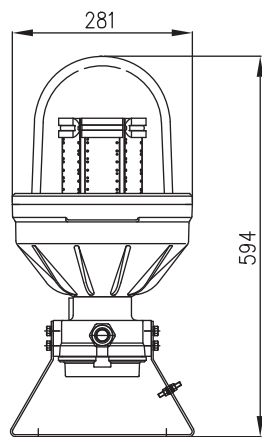

BEACON SIDE VIEW

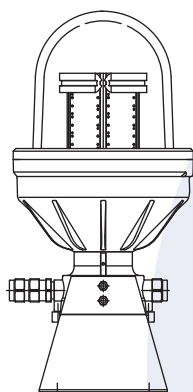

FIXING DETAILS

